



GRAPHIC  
WORKTOOLS

Ver. 2025-10

---

# Linear Cutter Series

## Blade Replacement Guide

Put the blade in down-position.

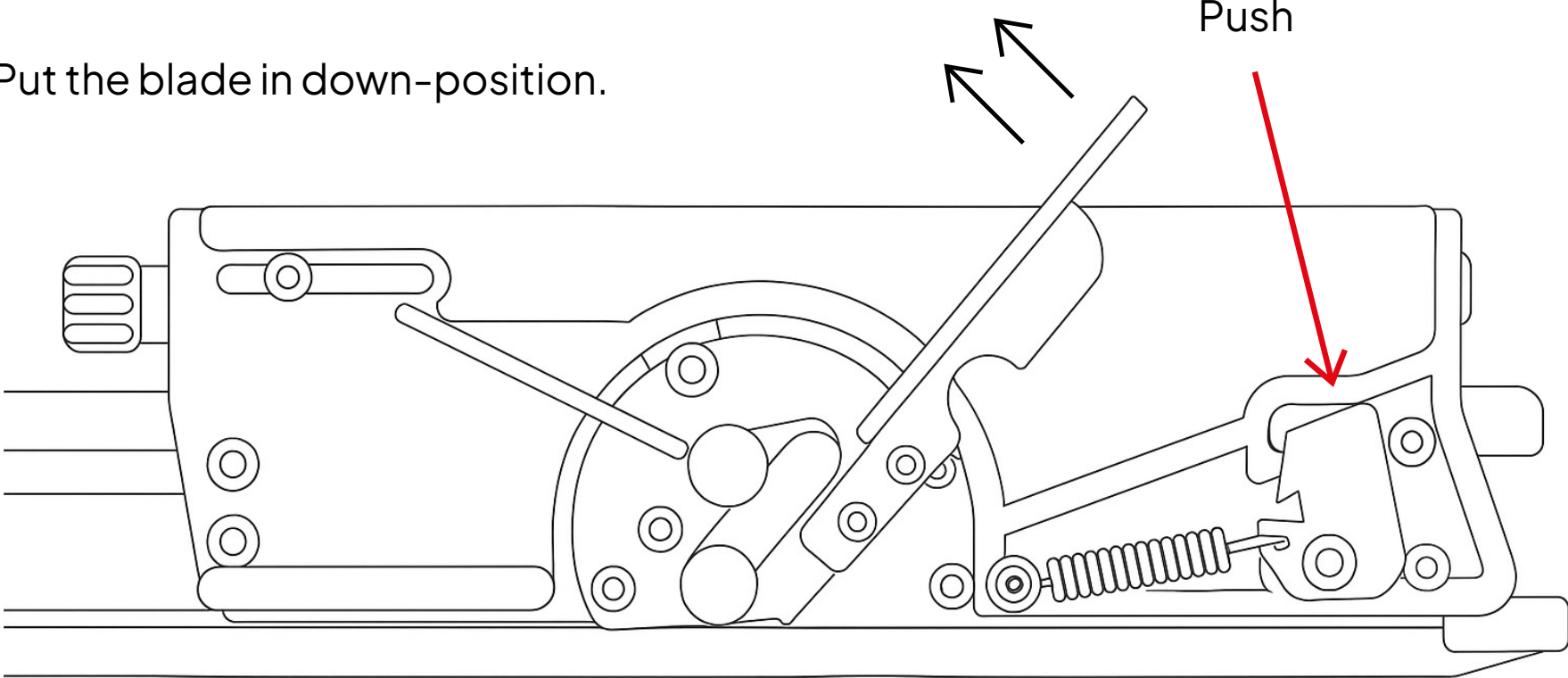

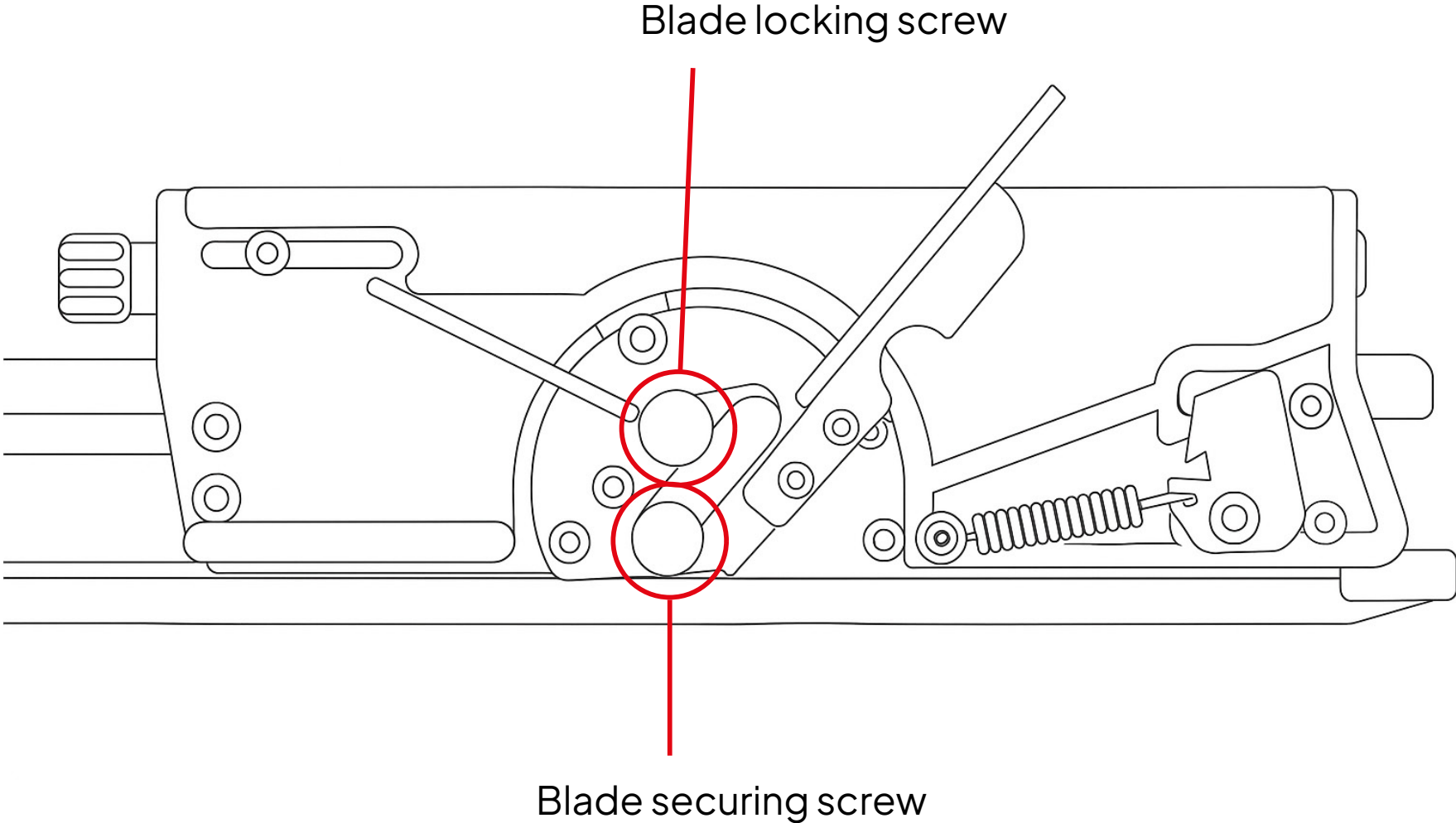



Place the new blade inside

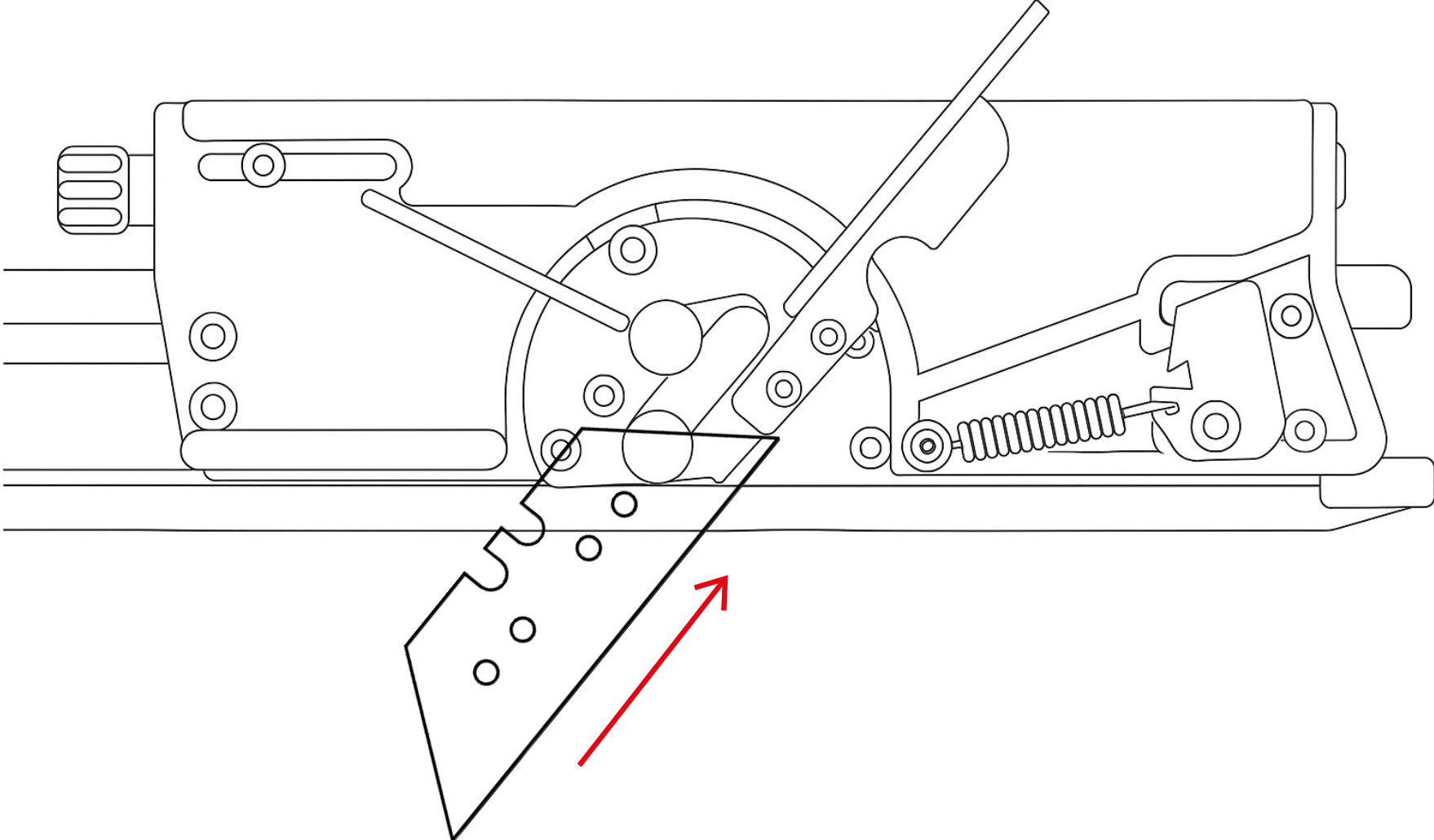

Align blade locking screw with notch 1

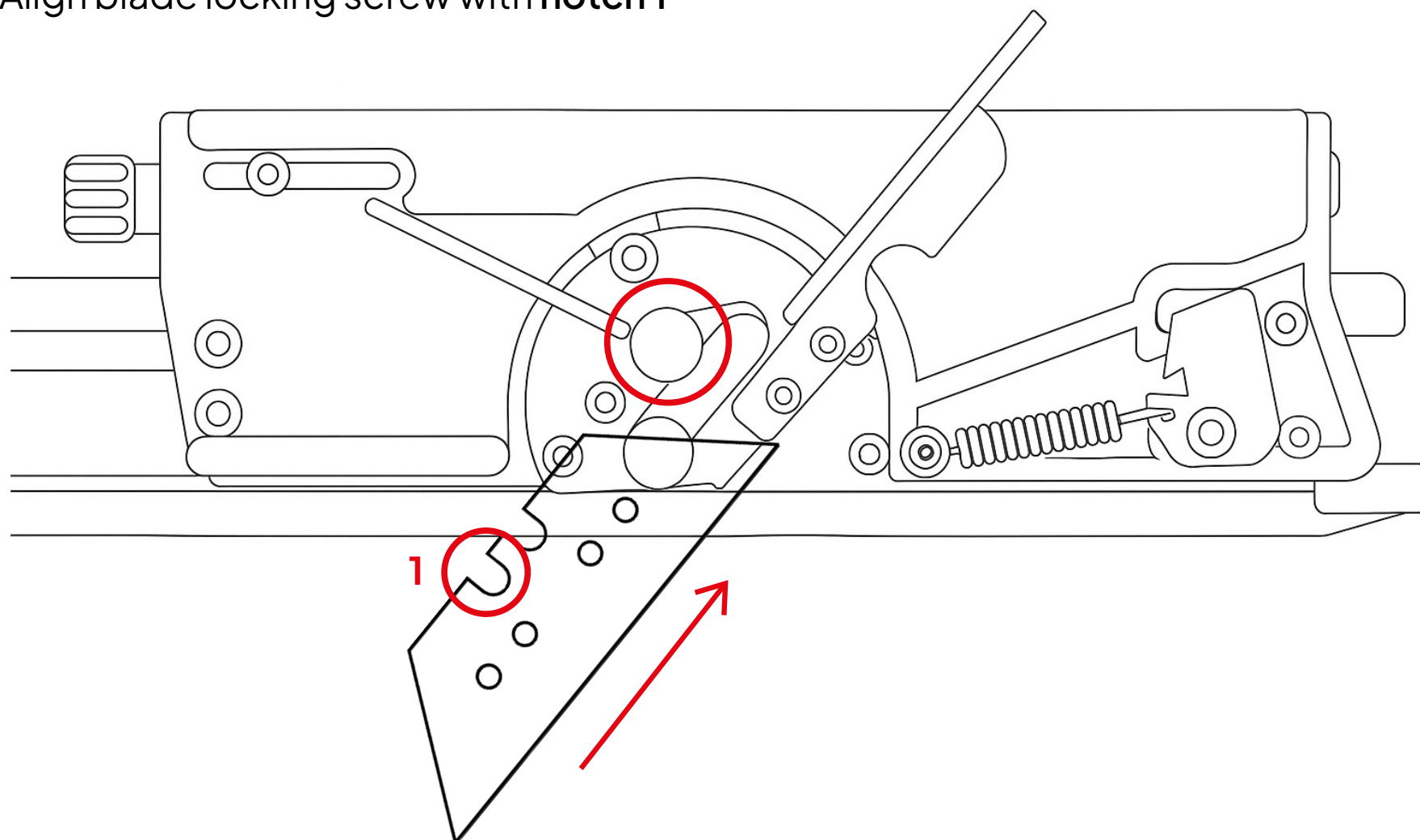

Mount the blade in notch 1 with the blade locking screw and secure the blade with the securing screw.

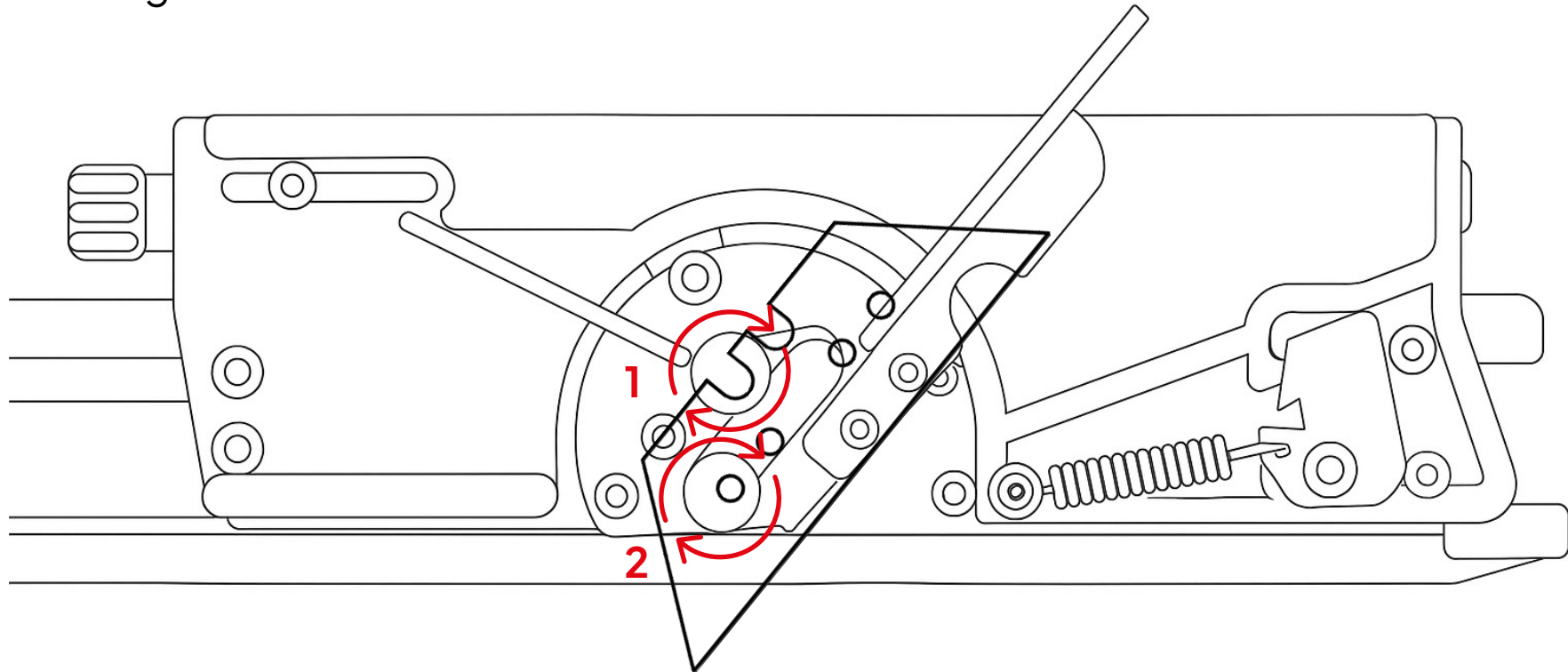

Use the adjusting screw to set the cutting depth to your preference.

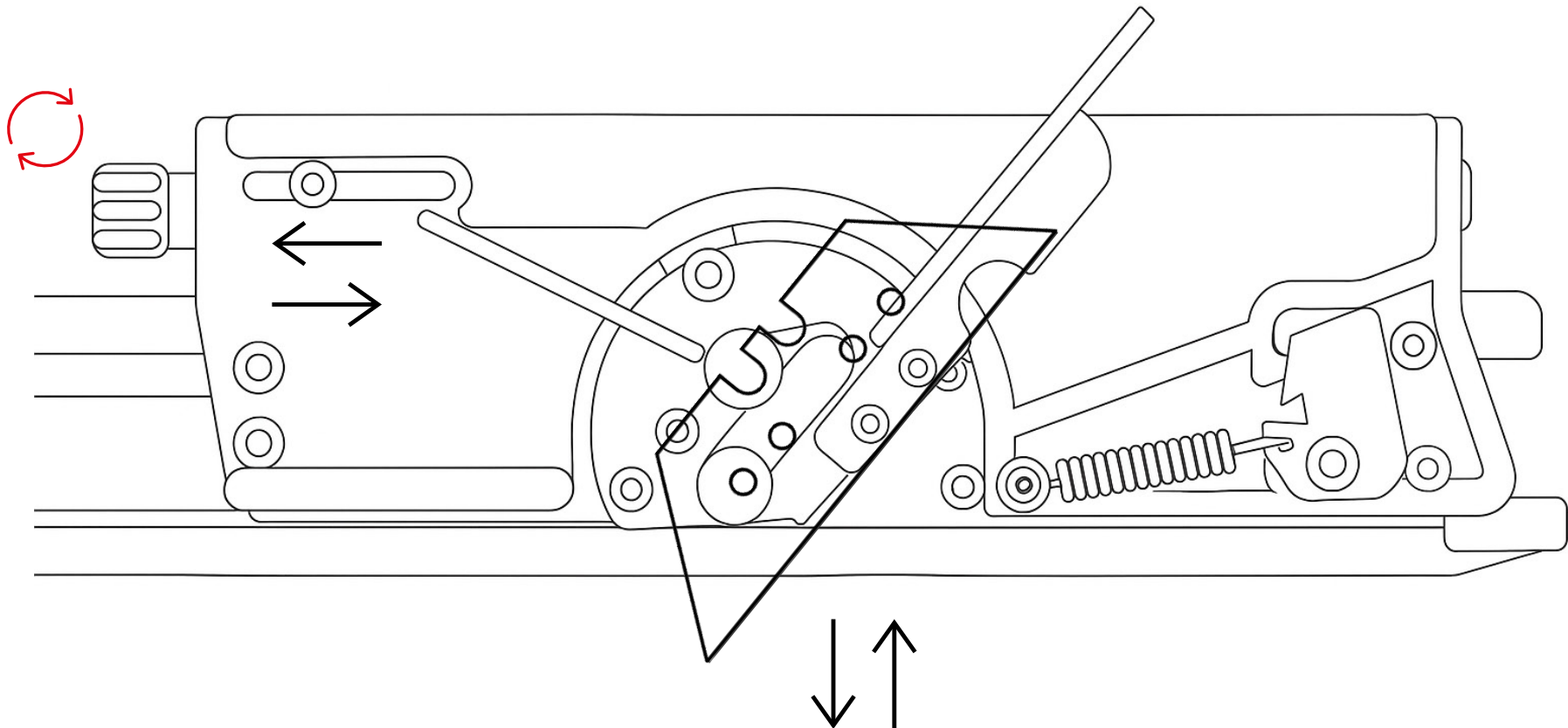

# CWT

---

GRAPHIC  
WORKTOOLS

Ver. 2025-10

---

CWT Worktools AB  
Årstidsvägen 8  
665 35 Kil

[cwtworktools.com](https://cwtworktools.com)  
[support@cwtworktools.com](mailto:support@cwtworktools.com)